

**SINGLE TURN
ABSOLUTE
ENCODER
380S**

Absolute single turn encoder, from 2 to 13 bits, in extremely sturdy housing for heavy duties.
Mechanic strength and accurate circuit design are its fundamental qualifications.

Absolute single turn
page: 01.380S 1/2
data sheet IA 031 E00

Measures without tolerance according to UNI ISO 2768-mk

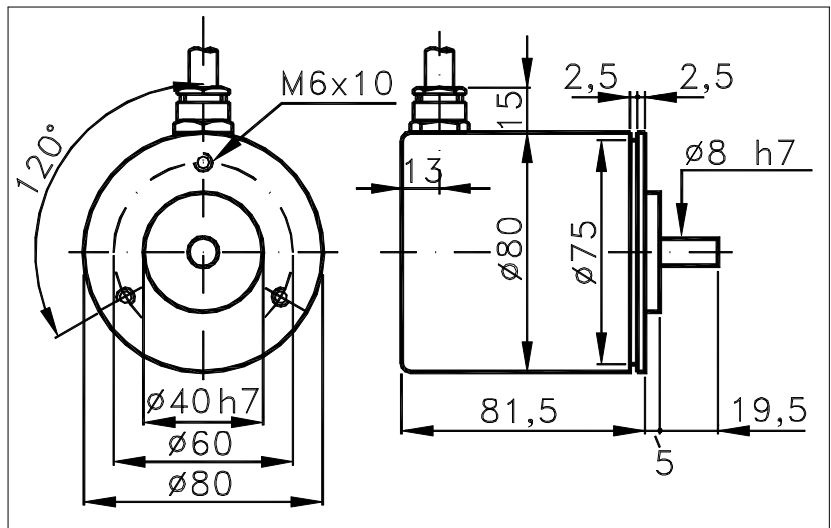

TECHNICAL FEATURES AND POSSIBLE CONFIGURATIONS

- Output codes.....: Gray, Binary, Excess, BCD, Custom
- Max pulses/rev.....: 8192 (13 bits)
- Power supply Vcc.....: 5±5%, 15±5%, 8+24, 18+28, 10+30
- Max consumption.....: 200÷400 mA accord. to bits (*)
- Light source.....: LED with >= 100000 h life
- Optical sensors.....: Phototransistors
- Max frequency.....: 50 kHz (*)
- Operating temperature.: 0 ÷ +70 °C (*)
- Storage temperature...: -30 ÷ +85 °C (*)
- Burn-in @ +75 °C.....: 72 h (*)
- Up/down commutation...: Ok
- Mechanical zero search: No
- Output stages.....: (-) NPN open coll.10mA(std)
(KK) NPN open coll.70mA + PTC
(KP) NPN open emitt.70mA+ PTC
(B) Push-p. 70mA+PTC 1÷12bit(1)
- Pre output interface...: (-) Parallel (standard)
(S) Serial SSI (1)
(A) Analogic 'current' (2) (*)
(V) Analogic 'voltage' (2) (**)
- Electronic options....: (F) Led zero
(for parallel interf.) (L) Latch (3)
(P) Parity
- Connections Radial (R): CV2 CD4 CM5 SM5 CM3 SM3 CL (4)
Axial (-) SL CH (*)
For the description of connections see 'ORDERING CODE' on page 2.
- Base.....: Aluminium (*)
- Cover.....: Aluminium painted (*)
- Weight.....: 800 g
- Shaft.....: Stainless steel (*)
- Max.rad/axial load....: 5 Kg
- IP output side.....: see 'CONNECTIONS' on page 2
- IP shaft side.....: std.65 | sealed 66 | low torq.-
- Contin. max RPM...(**): 6000 | 3000 | -
- Starting torque.. gcm.: 18 | 50 | -
- Impact resistance.....: 50 G (11 ms)
- Vibration resistance...: 12 G (10 ÷ 2000 Hz)
- Ball bearings life.....: 1,5x10⁹ revolutions
(@ 1000 rev/m with load of 1/4 maximum allowed)

POSSIBLE OPTIONS

CODE	DESCRIPTION	CODE	DESCRIPTION	CODE	DESCRIPTION
A	High temperature	X	Custom options	G	Tropicalization
L	Low temperature	H	Different shaft ϕ	Z	Sealed bal bearing
Y	Unbreakable disk	P	Compressed air attack		



ELCIS s.r.l. Via Rosa Luxembourg 12/14 10093 COLLEGNO (TO) ITALY
Phone: +39 011 715577/78 r.a.
MAIL: ELCIS s.r.l. P.O.Box 90 10093 COLLEGNO (TO) ITALY

* <http://www.elcis.com>
* e-mail: info@elcis.com
* Fax: +39 011 712613

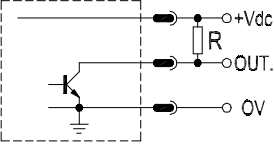
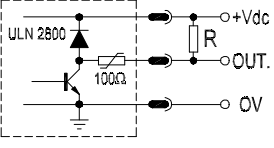
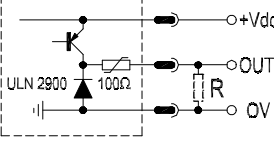
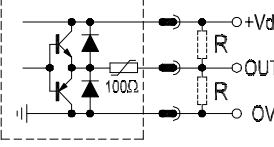
ELECTRONIC OUTPUT	INTERFACE	PARALLEL OPTIONS
» (-) NPN open coll.10mA(std) 	» (-) Parallel (standard) The angular value is present on the output connector in a 'parallel' form. The number of conductors is proportional to the resolution and the type of selected code. Any electronic output stage can be applied.	» (F)Led zero Designed for setting the encoder position with mechanical position. Led lights up at zero value with clockwise increasing code, at max. value with contrary clockwise.
» (KK) NPN open coll.70mA + PTC 	» (S) Serial SSI The data output (available only with Gray or Excess code) is controlled by an external clock. The angular position's value is first stored into the encoder and then transmitted outside starting from the MSB. The standard of transmission is RS422.	» (L)Latch When Latch input is set to 0 Vdc the outputs at Gray code disc level are 'frozen'; in such a way detections are carried out in stable conditions. For this reason Latch input is standard for Binary and BCD codes.
» (KP) NPN open emitt.70mA+ PTC 	» (A) Analogic 'current' » (V) Analogic 'voltage' Encoder's angular position with 10 bits resolution (1024 div./rev) is converted in an analog (mA or V) quantity proportional to its value. In the standard version (360° of rotation) Iu=1+20mA Vu=0+10V.	» (P)Parity An electronic circuit generates a signal (Parity) in such a way that the number of high level outputs is always odd; then there isn't any condition with all low level outputs. This option allows to carry out automatic checkout of the output stages.
» (B) Push-p. 70mA+PTC 1+12bit 		»

ORDERING CODE

Possible shaft Ø (n) Ø n upon req () () () () () () ()	(G) Gray (B) Binary (D) BCD (E) Excess (X) Upon request (-) Inter.A or V	(-) Parallel (standard) (S) Serial SSI (A) Analogic 'current' (V) Analogic 'voltage'	(CV2) 1 m long cable IP65 (CM5) Conn.26 pin PT02A16-26P IP65 (SM5) Conn.26 pin PT02E16-26P IP66 (CM3) Conn.23 pin PT02A16-23P IP65 (SM3) Conn.23 pin PT02E16-23P IP66 (CL) Conn.10 pin MS310A18-1P IP65 (SL) Conn.10 pin MS310R18-1P IP66 (CH) Conn. 12 pin Eml 121 IP65 (CD4) Conn.25 pin DB25P IP64				
	(-) NPN open coll.10mA(std) (KK) NPN open coll.70mA + PTC (KP) NPN open emitt.70mA+ PTC (B) Push-p. 70mA+PTC 1+12bit						
		only for parallel interface					
MODEL	CODE	RESOLUTION	POWER SUPPLY	OUTPUT ELECTR.	INTERFACE	CONNECT.	OUTPUT
A 380S	G	256	5	-	- -	CV2	R
OPTIONS	[*]				OPTIONS parallel interface	Axial Radial	(-) (R)
(A) High temperature (L) Low temperature (Y) Unbreakable disk (X) Custom options (H) Different shaft Ø (P) Compressed air attack (G) Tropicalization (Z) Sealed bal bearing ()	[*] Other resolutions on customer's requirement	(5) 5 V ±5% (1828)18 ÷ 28 V (15) 15 V ±5% (1030)10 ÷ 30 V (824)8 ÷ 24 V (X) Upon requ.			(P)Parity (L)Latch (F)Led zero		
		Cod. G, B, D: 8, 16, 32, 64, 128, 256, 512 Cod. G, B, : 1024, 2048, 4096, 8192 Cod. E, B, D: 10, 100, 500, 1000 Cod. E, B, D: 180, 360, 720, 900 Cod. E, B, : 1440, 1800, 2000, 2880, 3600, 4000					

Product manufactured according to UNI EN ISO 9001:2000, supplied with CHECKING and CONFORMITY declaration with CE mark and with TWO (2) YEARS WARRANTY starting from delivery date.

COPYRIGHT by ELCIS - Collegno (TO)

	ELCIS s.r.l. Via Rosa Luxembourg 12/14 10093 COLLEGNO (TO) ITALY Telefono: +39 011 715577/78 r.a. Corrispondenza: ELCIS s.r.l. P.O.Box 90 10093 COLLEGNO (TO) ITALY	* http://www.elcis.com * e-mail: info@elcis.com * Fax: +39 011 712613
--	---	---